

NIYANCELL BELT CONVEYOR SCALE

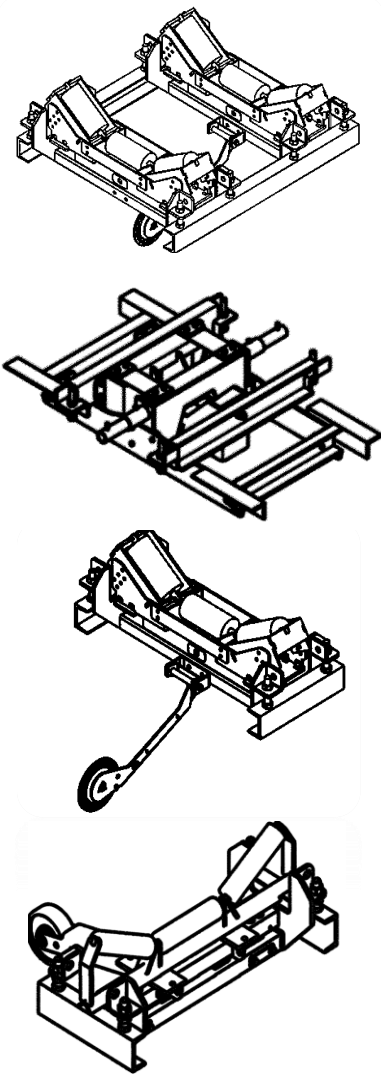

OPERATION • SELECTION • MAINTENANCE

NIYANCELL Belt Conveyor Scale Handbook

Mode BSM High Accuracy, Precision Certifiable Scale

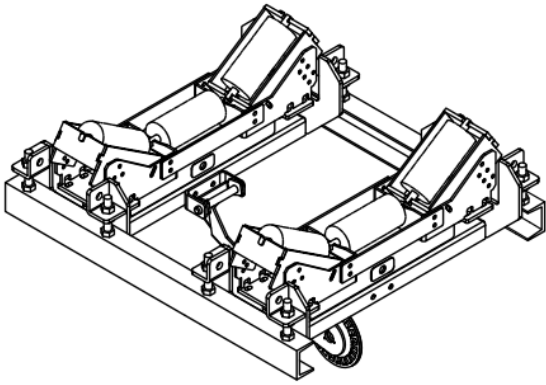

Specifically designed for high accuracy or basis-of-payment application requiring certification by government and regulatory agencies. It is extremely accurate to within 0.25% and is the most widely certified belt scale in the world. The NIYANCELL Series BSM lets you monitor production output and inventory, or regulate product loadout, while providing vital information for the effective management and efficient operation of your business.

Model WBD High Accuracy, Plant and Process Scale

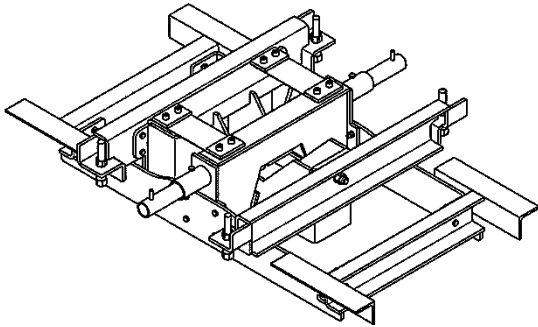

Specifically designed for plant and process operations that run at high rates of speed or require the better-than-normal accuracy of $\pm 0.25\%$. The NIYANCELL Series WBD provides vital information that allows you to effectively manage and efficiently operate your business by monitoring production output and inventory or regulating product loadout.

Model BSP Standard Plant and Process Scale

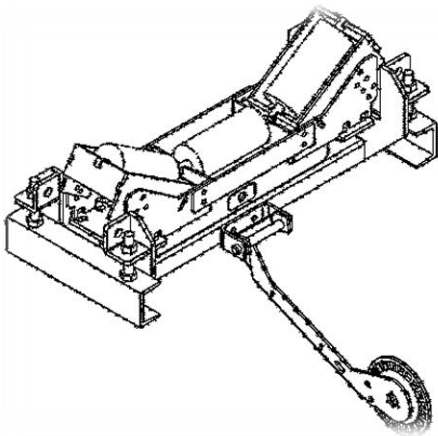

Monitors feed to crushers, mills, screens and other processes with an accuracy of $\pm 0.5\%$, even in the harshest applications. The NIYANCELL Series BSP lets you monitor production output and inventory, or regulate product loadout, while providing vital information for the effective management and efficient operation of your business.

Model BSS Basic process Monitoring Scale

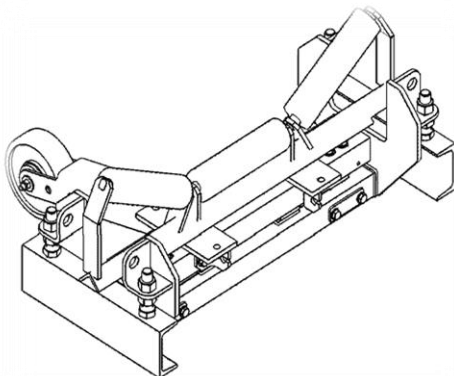

Provides basic rate information and totalization functions in processes involving noncritical or lower value materials with an accuracy of $\pm 1\%$. The NIYANCELL Model BSS belt scale system provides vital information that allows you to effectively manage and efficiently operate your business by monitoring production output and inventory or regulating product loadout.



Chapter 1 **Introduction** **Page 2**

Chapter 2 **General Theory of Operation** **Page 3**
Major components and design considerations

Chapter 3 **Weighing Accuracy** **Page 7**

Chapter 4 **Electro-Mechanical Belt Scales** **Page 8**

Chapter 5 **Selecting a Belt Conveyor Scale** **Page 9**
Intended Use / Accuracy / Belt Conveyor Scale Design / Conveyor Design / Calibration

Chapter 6 **Application of a Belt Scale** **Page 10**
Scale Location / Conveyor Design / Belt Scale Area Idlers

Chapter 7 **Continuing Maintenance** **Page 15**
Inspection of Belt Conveyor Scale Area / Periodic Calibration

Chapter 8 **Special Considerations for Weight Agreement Scales** **Page 16**
*(Certifiable Belt Scale Installations)
Compliance / Testing Procedures / Commitment and Responsibility*



Chapter 1

Introduction

A belt conveyor scale is a device that measures the rate at which bulk material is being conveyed and delivered on a moving conveyor belt. Further, it can compute the total mass of material conveyed over a given period of time. As the leading manufacturer of modern belt conveyor scales, we have not only pioneered the latest state-of-the-art technology, but has also installed thousands of belt conveyor scales worldwide. This experience has given us special insight into the problems and considerations of applying, operating and maintaining belt conveyor scales. In the following pages, we share that knowledge providing our customers, present and future, and other users of belt conveyor scales, a better understanding of applications and limitations.

Yes, belt conveyor scales do have limitations. Unfortunately, it is not as simple as just installing a piece of hardware in a conveyor to have a reliable scale installation. That is not to say the hardware isn't important—it is. That's why we have worked for years to develop the most reliable belt conveyor scale systems on the market.

We have pioneered the advances in belt conveyor scale electronics from early and simple analog circuits, through such improvements as zero and span calibration assists, electronic calibration and finally to microprocessor-based electronics with a wide array of automatic calibration features and self-diagnostic capabilities. But good hardware alone doesn't ensure a reliable and accurate belt conveyor scale. Of equal importance is how that scale is applied in a given conveyor and how it is operated, calibrated and maintained.

This handbook is designed to cover all factors affecting the reliable and accurate performance of belt conveyor scales of different types. The theory of operation and components of scale systems will be presented. The concept of weighing accuracy and how it is measured will be reviewed. Factors that affect weighing accuracy will be covered in detail. Other topics covered will include maintenance, calibration and special considerations for certified scale installations.

Please contact our office if you would like more information or to discuss a specific belt conveyor scale application.



Chapter 2

Theory of Operation

Belt conveyor scales provide a means of weighing bulk materials while in motion. The obvious advantage over static weight systems is that the flow of material need not be interrupted. As in batch weighing, accurate sensing of the weight of material is required.

Belt conveyor scales also require accurate sensing of the motion of the bulk material.

The weight on the conveyor belt is measured by sensing the force on one or more conveyor idlers. The motion of the material is measured by sensing travel of the belt with a device which produces an "output" representing a fixed distance of belt travel. Because the measured force represents weight per unit length (i.e., kg/m or lbs/ft), it can be multiplied by the belt travel to acquire total weight. (Example: $\text{kg/m} \times \text{m} = \text{kg}$; $\text{lbs/ft} \times \text{ft} = \text{lbs}$) This function can be accomplished with an electro-mechanical or electronic integrator.

With proper scaling, total weight may be accumulated in tons, long tons, or metric tons. In addition to displaying total weight passed over the belt conveyor scale, most modern integrators also display instantaneous rate (i.e. kg/hr or tons/hr) and provide transmitted outputs for remote monitoring and control requirements.

Most viable belt conveyor scale systems operate by the above mentioned method of measuring weight per unit length and multiplying that by belt travel to determine total material weight. To better understand the theory of operation of all belt conveyor scales, the following paragraphs describe the individual components of a scale system in greater detail.

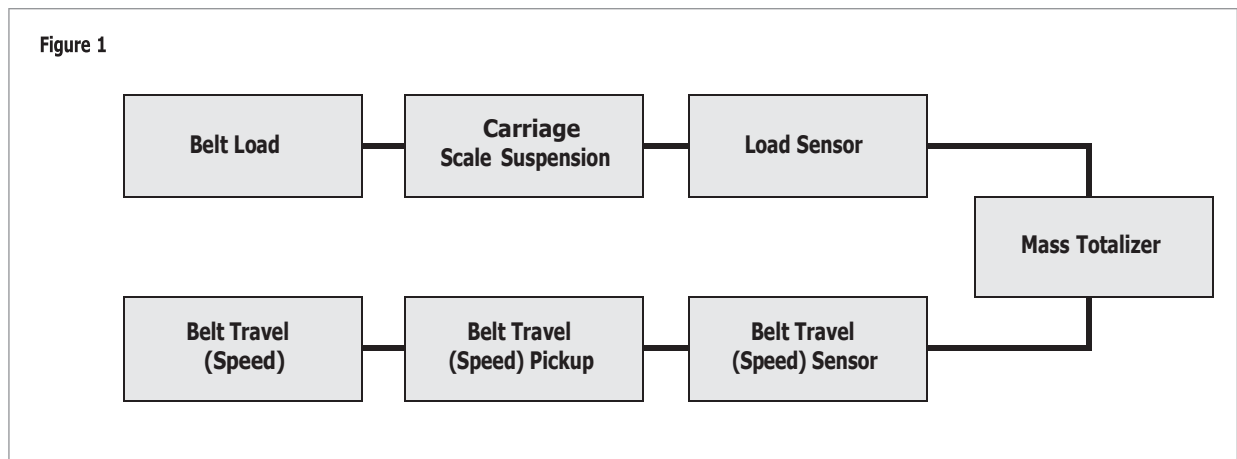

Major Components of a Belt Conveyor Scale System

The basic components of a belt conveyor scale are shown in Figure 1. Their functions are as follows:

- The scale carriage (scale suspension) transmits the forces resulting from the belt load and directs those forces to the load sensor(s).
- The load sensor(s) transduces the load force to a form acceptable to the mass totalizer.
- The belt travel (speed) pick-up contacts the belt and transmits belt travel (speed) to the speed sensor.

The belt travel (speed) sensor transduces the belt travel (speed) to a form acceptable to the mass totalizer.

- The mass totalizer (integrator) computes the total mass that has passed over the belt conveyor scale and provides for indicating and recording that value. Typically, the mass totalizer will also provide a mass flow rate indication.

Various designs and technology can be applied to the components of a belt conveyor scale, but basic design considerations are applicable to all.

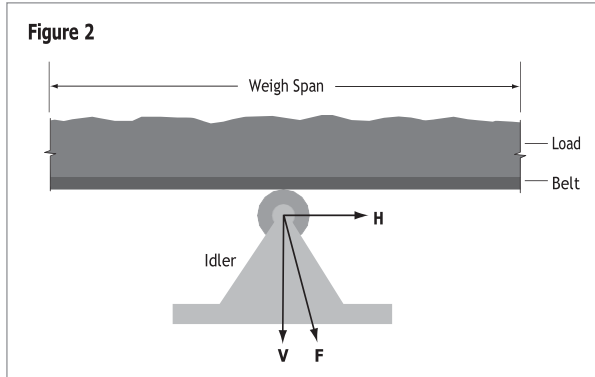

Scale Carriage

The scale carriage must transmit the forces resulting from material on the conveyor belt to the load sensor without adding any extraneous forces. It is important that no forces originating from belt travel or belt side travel be converted to a force on the load sensor.

Figure 2 is a sketch of a single weigh idler showing forces in two dimensions. The force F actually is sensed by the idler, but the scale carriage must transmit only force V to the load sensor. Force H (as well as another force H vertical to the plane of the figure) must not be changed to a force acting on the load cell as a false representation of force V .

In general, to accomplish this function, the scale carriage must fulfill the following criteria:

1. Rigidity, minimal deflection
2. Torsional stability
3. Elimination of the effects of lateral forces
4. Minimize effects of off-center belt loading
5. Alignment provisions
6. Minimize tare weight portion on sensor
7. Maximize belt load portion on sensor
8. Minimize horizontal surface area for dirt collection
9. Unit construction for easy installation
10. Frictionless pivot points or fulcrums
11. Provisions to accept high temporary overloads without calibration shifts

Several common carriage designs are shown schematically in Figure 3

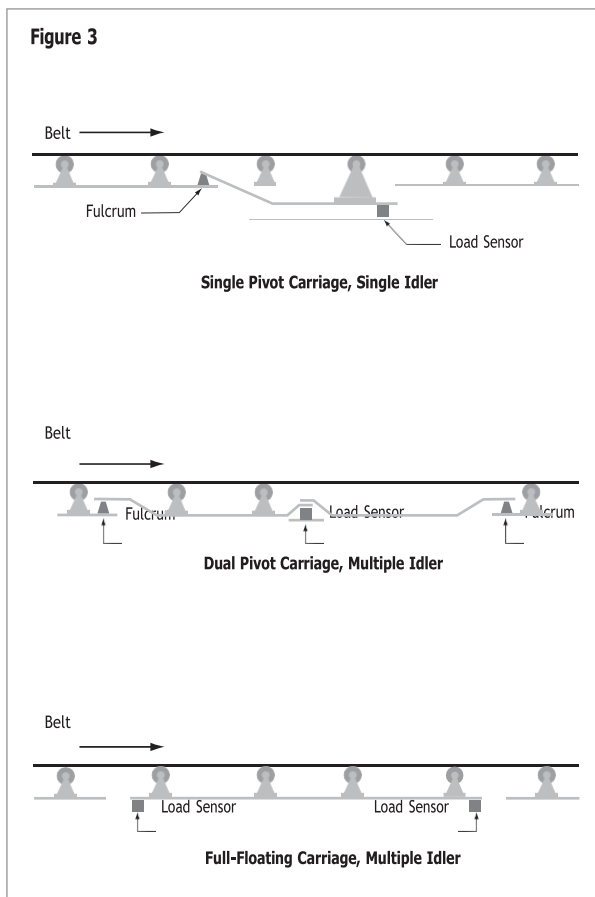

Load Sensor

The load sensor(s) receives the force transmitted by the scale carriage and converts the force to a signal usable by the mass totalizer (integrator).

Several means of load sensing have been used in belt conveyor weighing, including mass balance, force balance using buoyancy of a displacement float, pneumatic or hydraulic force balance, magnetic force balance, and deflection or spring type transducers which include both strain gauge load cells and LVDT (linear variable differential transformer) load cells.

Each of the above techniques has certain advantages and disadvantages. One important factor for belt conveyor weighing is minimum deflection from no load to full load. Strain gauge load sensors typically have less than .08mm (.003 inch) deflection as used in conveyor scales and are the most commonly used load sensor. Another important factor is temperature stability. Since most belt conveyor scales are installed outdoors, the load sensor must be able to operate over a wide temperature range without appreciable zero-drift and error due to temperature. Here, again, strain gauge load cells have an advantage over some other types of load sensors.

Belt Speed (Belt Travel) Sensors

Belt speed or belt travel sensing (displacement) is equally important to the accurate measurement of load in the computation of total mass passed over a belt conveyor scale. A one percent error in conveyor speed (travel) measurement will produce a one percent error in the totalized value just as surely as a one percent error in load sensing.

Errors in the accurate measurement of belt travel for weighing can occur from a variety of sources.

1. Slip between the belt travel pick-up (roller or pulley) and the conveyor belt.
2. Belt travel pick-up axis not exactly 90° to the direction of belt travel (narrow wheel type pick-ups).
3. Belt speed varies within the conveyor as a function of tension.
4. Inaccuracies within the speed sensor (speed transducer).
5. Material build-up on the belt travel pick-up.
6. Wear or deterioration of the lagging on the belt travel pick-up. The function of the belt travel pick-up is to provide a rotary motion suitable for the belt travel sensor and representative of the actual conveyor belt travel at the load sensing location. Due to changes in belt tensions, differences along the conveyor of 0.3 to 0.5% have been observed. For this reason, it is preferable that the belt travel pick-up be mounted near the scale location. Note that the return portion of the conveyor does not conform to this definition of "near the scale location."

Table A

	Advantages	Disadvantages
Tail Pulley	<ol style="list-style-type: none"> 1. Large angle of wrap. Low slip. 2. Large diameter - not normally affected by material build-up, small effect from belt thickness variations. 	<ol style="list-style-type: none"> 1. If scale is at high tension compared to tail pulley, belt speed will be somewhat higher in scale area.
Underside of Load Carrying Portion of Conveyor	<ol style="list-style-type: none"> 1. Can be mounted near the scale location to avoid speed errors due to tension changes. 	<ol style="list-style-type: none"> 1. Very small portion of wrap, has high potential for slip. 2. Often a narrow pulley which can easily be installed with an axis not at 90° to belt travel.
Roller Mounted to Clean Side of Return Portion of Conveyor	<ol style="list-style-type: none"> 1. Usually a full width roller which can readily be installed at 90° to belt travel. 2. If an extra pulley is installed, adequate angle of wrap can be provided. 	<ol style="list-style-type: none"> 1. Has even more tension variation than tail pulley location. 2. Requires installation of special roller or rollers. 3. Smaller diameter is affected by belt thickness variations or material build-up.
Modified Conveyor Idler	<ol style="list-style-type: none"> 1. Can be mounted at the scale location to avoid speed error due to tension changes. 	<ol style="list-style-type: none"> 1. Very small angle of wrap, has high potential for slip. 2. Requires special idler.



Some of the most common forms of belt travel (speed) pick-up are as follows:

1. The tail pulley.
2. A pick-up mounted to ride against the underside of the load carrying portion of the conveyor.
3. A roller mounted to ride against the clean surface of the return portion of the conveyor.
4. A conveyor idler modified to provide speed sensing. Table A provides a summary of some of the advantages and disadvantages for each system.

Belt Travel Sensors

Devices used for sensing belt travel have included DC generators, AC generators, mechanical belt or chain devices for mechanical integrators, photo-optical segmented disks, and electromagnetic pulse generators. These devices transduce the belt travel to a signal suitable for the mass totalizer.

With the advent of microprocessors, it has become more appropriate to use a device which provides a pulse for each unit length of belt, as described in the section on mass totalizers.

Mass Totalizer (Integrators)

Outputs from the belt travel (speed) sensor and from the load sensor are combined in the integrator to produce a running total of material passed over the belt conveyor scale. (Both mechanical and electronic integration have been used. Mathematically, there are two classes of integrators which will be referred to as a weight integrator and a rate integrator.

The weight integrator senses load and belt travel. The device then computes the total weight according to the equation:

$$\text{Where: } WT = \int Q dx$$

$z = \text{Total Weight}$
 $Q = \text{Weight of Material per Unit Length of Belt}$
 $Dx = \text{Infinitesimal Length Element of the Belt}$

In the newer digital totalizers, the equation is more correctly stated:

$$\text{Where: } WT = N \sum Q_i$$

$z = \text{Total Weight}$
 $Q_i = \text{Wt on Scale at Instant } i$
 $i = \text{Unit Length of Belt as Unitized by Integrator}$

The rate integrator multiplies the load by the belt speed to get a weight per unit time signal, then integrates:

$$\text{Where: } WT = \int Q v dt$$

$z = \text{Total Weight}$
 $Q = \text{Weight per Unit Length}$
 $v = \text{Belt Speed}$

To provide accurate total weight and convenient operation, the integrator should contain such features as:

1. Stability of gain and zero over the operating temperature range, typically -10°C to +40°C (+15°F to +115°F). Change across the range should be less than the accuracy statement.
2. Ability to integrate both plus and minus for accurate zeroing.
3. Belt speed compensation.
4. Convenience of operator use for calibration.
5. High resolution for calibration.
6. Non-interacting zero and span adjustments. Digital systems are available with no screwdriver adjustments, only keyboard inputs.
7. Compatibility with instrumentation and control.
8. Auto zeroing capability.
9. For low accuracy installations, a low load cutout may be convenient.

Most present-day conveyor scales use some form of electronic integrator. They are divided into three categories:

1. Analog mathematics
2. Frequency counting mathematics
3. Microprocessor mathematics

Detailed discussion of these devices is beyond the scope of this handbook.

All the components described must function accurately with minimal error for a belt conveyor scale system to perform accurately.



Chapter 3

Weighing Accuracy

It is important to establish a clear definition of weighing accuracy for belt conveyor scales. Consider the meaning of accuracy as it applies to a platform, truck or hopper scale. The scale is checked for accuracy against a traceable standard weight. For smaller capacities, the weights may be used to full capacity. For larger capacities, a substitution test may be used where standard weights are applied, then removed and material added to that same percent of capacity. In either case, notice the presence of traceable standards of mass which are applied to the scale.

In the case of the belt conveyor scale, this procedure cannot be followed. It is certainly possible to apply traceable weights to the belt conveyor scale, but the procedure has little meaning. The actual mass as seen by the conveyor scale in operation is affected by the conditions of the conveyor belt, as well as by the actual mass passing over the scale. As a result, the only way to test the accuracy of the belt conveyor scale is to compare the weight of material weighed over the belt conveyor scale to a reference static scale. This immediately raises several other questions:

1. How much mass should be collected?
2. How accurate is the reference scale?
3. What if it isn't possible to collect the material?

National Institute of Standards and Technology Handbook 44 contains a section covering conveyor scales. Paragraph N2 defines the minimum mass to be collected as:

- (a) not less than 800 scale divisions,
- (b) at least three revolutions of the belt, and
- (c) at least ten minutes operation, or for a normal weighing. In addition to defining the minimum mass to be collected,

Handbook 44 also requires it to be collected at normal use capacity, and flow rates as low as 35% of rated maximum. Defined series zero load tests must also be run prior to the material test.

The rationale for these requirements is based on the properties of a belt conveyor scale. The ten minutes duration is an acknowledgement that the mass measurement in the conveyor scale contains appreciable amounts of process noise and it is necessary to average this noisy signal over some period of time. For example, NIYANCELL Scientific scales average a minimum of 10 times per second; therefore, the 10 minute period is an average of 6000 observations.

Three circuits of the belt is an acknowledgement that the conveyor belting is not perfectly uniform. Some sections of the conveyor belting will be heavier than others. The best test is one in which the test includes an exact unit number of revolutions of the belt.

The requirement for a minimum of 800 scale divisions on the master weight totalizer is to provide a minimum resolution of one part in 800 in the conveyor scale reading.

These requirements can, in some cases, result in a different quantity of material. For example, a conveyor scale operating at 5000 tons per hour will yield 833 tons in 10 minutes. If loaded into 100 ton rail cars, this is a minimum of 9 cars. This, in turn, requires 9 gross weights and 9 tare weights, each with some error, to establish the reference weight against which the conveyor scale is to be calibrated. It is always important to verify the accuracy of the reference scale prior to any calibration of the conveyor scale. Accuracy for a conveyor scale is then calculated by:

$$\frac{\text{Reference Scale Value} - \text{Conveyor Scale Value}}{\text{Reference Scale Value}}$$

A WEIGHED MATERIAL LOAD TEST IS THE ONLY WAY TO ESTABLISH TRACEABLE ACCURACY ON A BELT CONVEYOR SCALE.

Other types of tests (referred to as simulated tests) are often used with conveyor scales, such as test chains applied to the carrying surface of the belt, known weights applied statically to the conveyor scale, or shunt resistors of known value applied to the strain gauge bridge. None of these simulated tests can establish accuracy. In some cases, they may be useful in determining repeatability and stability of the scale electronics.

Often, a simulated calibration test is the only reasonable way to calibrate a belt scale. It may be very difficult in some material handling systems to isolate a sample which can be taken to a certified static scale, especially a sample of large size. The location of the nearest certified track or truck scale could also be a considerable distance away, making it very costly and time consuming to run a material test. One solution is to install a certifiable test weigh bin as part of your material handling system.

Regardless of your installation, it is important to keep in mind what factors contribute to accuracy in a belt scale system and that, because of the dynamic effects of weighing-in-motion, a weighed material test is the only way to verify system accuracy as opposed to repeatability.



Chapter 4

Electro-Mechanical Belt Scales

The previous discussion has outlined the basic theory of operation, design considerations and concept of weighing accuracy as generally applicable to all types of belt conveyor scales. The three basic types of belt conveyor scales encountered in the field are nuclear, mechanical and electro-mechanical.

Mechanical scales are representative of older technology and their usage is very limited. Nuclear scales measure material density and not weight. Varying density or moisture content will result in significant weighing inaccuracies. Electro-mechanical scales are by far the most widely used type today. Often referred to as electronic belt conveyor scales because data is transmitted and processed electronically, electro-mechanical scales still must mechanically interface with the conveyor itself to measure the mass load on the belt.

Though we refer to an electro-mechanical belt conveyor scale as a type, there is still a great deal of diversity between various electro-mechanical belt conveyor scales on the market. The different manufacturers take varying approaches to the design of the components that comprise their system. Even a single manufacturer may have significant differences between models in their line, varying in capabilities and features. This is evident in all four components that make up a belt conveyor scale system; carriage, load sensor, belt travel (speed) sensor and integrator.

Carriages, for instance, come in a wide variety of designs, but all generally traceable to the three basic types described earlier in Figure 3. The only generalization that can be made about carriage is that the longer multi-idler versions are usually associated with higher performance systems while single-idler carriages are widely used for most general in-plant control and monitoring applications.

The load sensors used on electro-mechanical scales are electronic transducers, usually either LVDT's or strain gauge load cells, the latter being most widely used.

Speed sensors all generate an electronic signal, but vary considerably in their design and the point at which a given manufacturer usually applies them. Almost all variations discussed earlier in Table A are used by one manufacturer or another.

Finally, integrator/totalizers are electronic, but can vary considerably in their design, features and specifications. Both analog and digital designs are offered in the marketplace. Those designs offering the most current technology are microprocessor-based digital units with software that provides simpler calibration and self-diagnostics.

In summary, even among the broadly used electro-mechanical scale type, a wide selection of product designs and features are offered. Each manufacturer will have an argument supporting its own design and methods. Hopefully, after reading this handbook and understanding the theory of operation and design considerations for belt scales, the reader will be able to ask intelligent questions and better evaluate the choices available.

The following sections on selection, application and maintenance of belt scales are offered primarily with the electro-mechanical belt conveyor scale in mind.



Chapter 5

Selecting a Belt Conveyor Scale

The process of selecting a belt scale that is best for any given situation should take into consideration all of the following: (1) intended use, (2) accuracy, (3) belt scale design, (4) conveyor, and (5) calibration. The following is a discussion on each of these points.

1. Intended Use:

It is generally agreed that people purchase a belt scale for three distinct uses:

- a. Fee or custody transfer application. Typically, these scales require accuracies within 1/4% and require a regulatory agency approval.
- b. Process management or control application. These scales are used in process plants to monitor costs, production rates, and blending of material. The accuracy levels desired range between $\pm 1/4\%$ and $\pm 1\%$, depending on the situation. Belt conveyor scales rated for $\pm 1/2\%$ accuracy are most common for these applications. Typically, they do not require agency approval.
- c. Process monitor application. These scales are used in process plants to get an alarm when potentially costly or harmful situations exist, such as too much feed to a crusher. The accuracy levels range between $\pm 1/2\%$ and $\pm 3\%$, depending on the situation. Often repeatability is of equal concern as actual weighing accuracy.

2. Accuracy:

The accuracy statements printed on the sales literature of each company manufacturing belt conveyor scales is different. Some state the accuracy of the instruments and not the complete system. Others give a repeatability statement, meaning simply that it will repeat within certain limits when checked against simulated tests. Still others state that on the installed system, over a specified operating range, the belt conveyor scale system will weigh to a certain accuracy. Traceable accuracy may be established by conducting a material test in accordance with Handbook 44.

3. Belt Conveyor Scale Design:

The belt conveyor scale, as received from the manufacturer, has three major components; namely, the electronics, speed sensor and carriage assembly (which includes the load sensor). The following are things to consider:

- a. Electronics – Is it current state-of-the-art? Is the sum of errors (linearity and temperature stability) considerably less than the system accuracy required? In other words, the error of the electronics must be small compared to the system accuracy. Do the electronics feature automatic span and zero

calibration? Can the electronics assist in diagnosing and displaying error or operating problems? Are proper outputs and displays available? Are output signals isolated?

- b. Carriage Design – Here, two basic designs exist: (1) pivoted type, and (2) full-floating platform (refer to Figure 3). The following is a comparison of the two designs:

- (1) Pivoted Design – In the pivoted design, the weight applied to the weigh idler(s) results in the torque about the pivot. This torque is measured by the load cell. The torque and weight will have a linear and stable relationship as long as the pivot is perfect. Pivots made from knife edges and ball bearings develop flat spots, with time making them far from a perfect pivot. The result is weighing errors of measurable size.
- (2) Full Floating Design – In this design, there are four (4) load cells to suspend the carriage and sense the weight. No pivots and no torques – only check rods to hold the weighing platform in place. This is the same principle used in accurate static scales. For high accuracy weighing, microprocessor-based electronics and a full-floating design carriage have proven to be extremely accurate and reliable.

4. Conveyor Design:

Review the following “Application” section for conveyor considerations. Remember that for the high accuracy, all suggestions of that section must be addressed.

5. Calibration:

The calibration of a belt scale is completely different from a static scale simply because it is a dynamic scale, meaning the material is moving. To calibrate a belt scale involves using a simulated load for initial calibration, followed-up by a material test. Subsequent calibration checks are normally done with simulated loads.

If they occur more often than a planned schedule of, say, one a month, they can be costly in terms of time and labor.



Chapter 6

The Application of a Belt Scale

Assuming you have selected good scale hardware, the application and installation of your belt conveyor scale now becomes all-important in determining how accurately your belt conveyor scale system will perform.

In applying belt conveyor scales, one must always consider external influences originating from the material handling system and conveyor belt. Regardless of stated accuracies, these two factors will determine the overall long-term and short-term accuracy you may expect. The following guidelines should be adhered to in order to optimize belt scale performance and weighing accuracy.

1. Scale Location:

a. Tension:

In all installations it is very important that the belt scale be installed in an area where belt tension and tension variations are minimal. For this reason, the belt scale should be installed near the tail section of the conveyor, but far enough forward so as not to be influenced by infeed skirt boards.

Figure 4

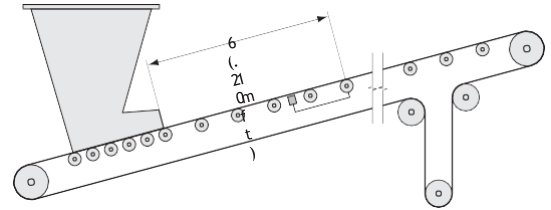

b. Uniform Belt Loading:

Although in most applications the scale system is capable of operating accurately over a 4 to 1 range, it is desirable that the belt loading be as uniform as possible. To minimize surges or feed variations, hoppers, if possible, should be equipped with depth limiting gate or other flow control device, such as a feeder.

Figure 5

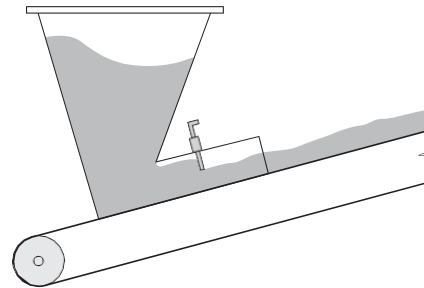

c. Single Load Belt:

On high accuracy installations, the conveyor should be loaded at one and the same point. This assures constant belt tension at the scale during all loading conditions.

Figure 6

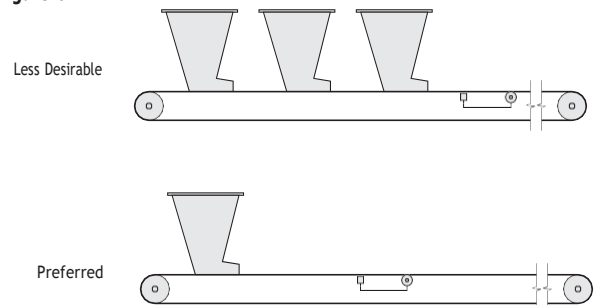

d. Material Slippage:

The belt scale system processes belt loading and belt travel to arrive at an accurate weight. Product speed must equal belt speed at the scale. For this reason, the conveyor speed and slope should not exceed that at which material slippage occurs.

Figure 7

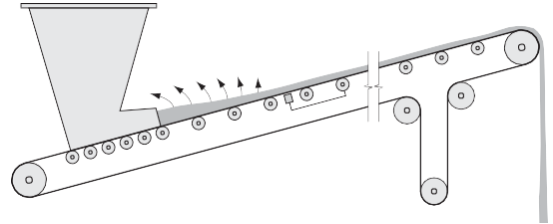

e. Convex Curves:

Straight conveyors are preferable to curved conveyors. Curves are not recommended between the loading point and the scale. Convex curves are permissible at a distance of 6 m (20 ft) or a minimum of five idler spaces beyond the scale area idlers.

Figure 8

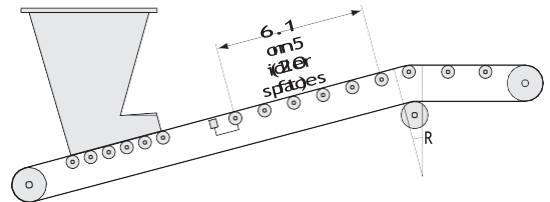

f. Concave Curves:

If there is a concave curve in the conveyor before or after the scale, the scale shall be installed so that the belt is in contact with all the idler rollers at all times for at least 6 m (20 ft) or 5 idler spaces, whichever is greater, before and after the scale. A concave curve shall start no closer than 12 m (40 ft) from the scale to the tangent point of the curve.

Figure 9

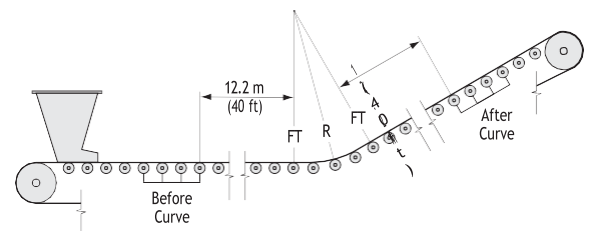

g. Trippers:

In any installation where weighing accuracy is important, the scale system should not be applied to a conveyor that has a movable tripper. If the scale must be installed on a conveyor with a tripper, then the same rules apply as for an installation in a concave conveyor. The minimum distances outlined in the above paragraph must be adhered to with the tripper in its fully retracted position. It is also of extreme importance that the belt tracks centrally at the scale area for all tripper locations.

Figure 10

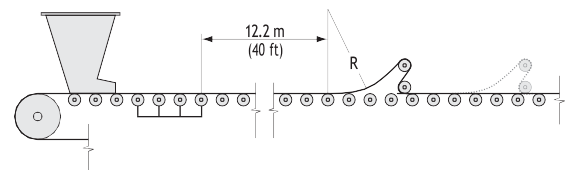

2. Conveyor Design:

a. Wind and Weather Effects:

The scale and conveyor at the scale shall be protected from wind and weather effects. Magnitude of weighing errors caused by wind is dependent on wind velocity. A minimum of 6 m (20 ft) should be enclosed or shielded on either side of the scale. A door on one end is recommended.

Figure 11

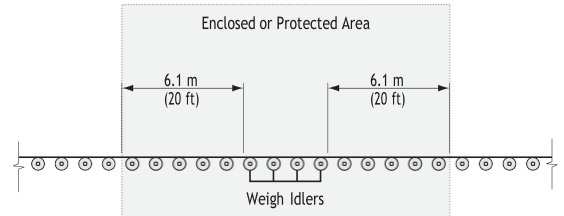

b. Vibration and Deflections:

The entire conveyor frame should be isolated from bins, feeders, crushers, and other mechanical equipment. This is to prevent bin loading from causing conveyor deflections and to protect the weighing equipment from vibrations and shocks imposed by mechanical equipment.

c. Conveyor Support:

In the design of the scale system, several deflections are taken into consideration. These are the deflection of the load cells, and the deflection of the supporting conveyor structures. It is of utmost importance that these deflections not be excessive. In the manufacture of the scale, the amount of deflection in the load cells and the carriage assembly is controlled. The only variable is the deflection of the conveyor itself. Therefore, the conveyor stringers supporting the scale and idlers to either side of the scale should be so designed that the deflection between any two adjacent idlers within the weigh area does not exceed 0.025 inch (0.6 mm) under load. No conveyor expansion joints should be located in this region of the conveyor.

Figure 12

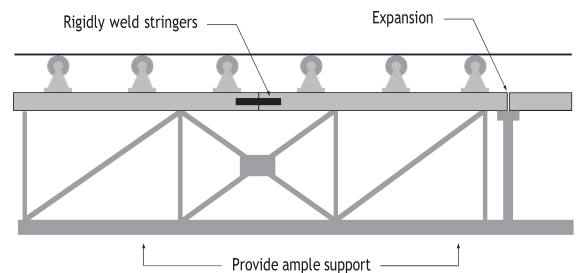
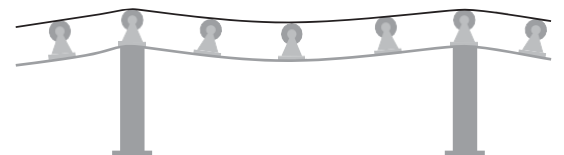

Figure 13



d. Cable Conveyors:

Conveyors commonly known as "CABLE" or "ROPE" conveyors are not suitable for electro-mechanical belt conveyor scale weighing unless a rigid conveyor section long enough to support the scale and scale service idlers is added.

e. Stacking Conveyors:

Avoid cable supported conveyors such as stacking conveyors and conveyors that change the angle of elevation between periods of calibration. This application is possible at reduced accuracy.

Figure 14

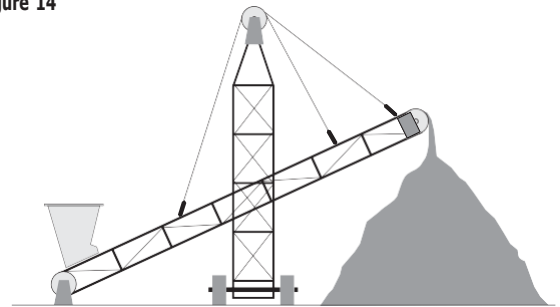

f. Gravity Type Take-Ups:

All conveyors over 9 m (30 ft) in length should be equipped with a gravity type take-up.

Figure 15

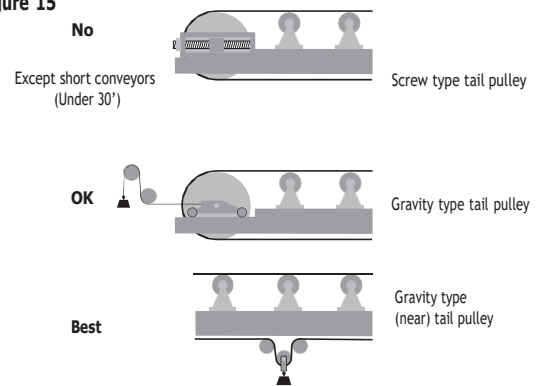

g. Belt Tracking:

One problem in attaining optimum belt scale accuracy is the effect of belt tracking from an empty to a fully loaded condition. To enhance belt tracking, the construction of the belting should have the necessary flexibility to ensure contact with all scale area idler rolls when the belt is running empty. In addition, this also ensures that the conveyed material is being supported by the weighing idlers rather than by the carcass of the conveyor belting. In no case should the belt extend beyond the edge of the idler roller over the entire length of the conveyor.

Figure 16

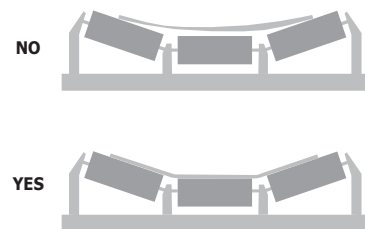

3. Belt Scale Area Idlers:

a. Idler Type:

The selection of the idlers used within the scale area is extremely important. This pertains not only to the idler type, but the idler construction itself. Since idler alignment plays an important role in the operation of a belt conveyor scale, it is extremely important that all idlers be manufactured as nearly alike as possible. It is also important that certain types be avoided, such as "V" types and rope or cable types. Offset idlers may be installed on full floating carriages but should not be used on single or dual pivoted carriages.

Figure 17

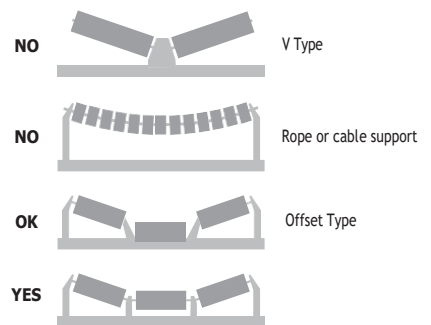

b. Scale Service Idlers:

Idlers in the weighing area (minimum +4 to -4 idlers and on scale) should be round, uniform and of same make, troughing angle and rating. The top grade idler, manufactured by most of the major idler suppliers, under normal conditions, is an adequate idler for scale service use. It may be required, however, to select a series of idlers that have similar dimensions and troughing angles for scale service.

c. Idler Troughing Angles:

The use of idlers with steep troughing angles causes many problems. Not only does the beam or catenary effect of the belt become more pronounced as the troughing increases, but the effect of idler misalignment is amplified as well. One very important function to perform at the time of installation of the scale system is to check out the alignment of all idlers within the weighing area. This is done to help minimize the extraneous forces introduced into the weighing system caused by changes in belt tension or other external forces as the belt travels across the idlers. Troughing angles of 35° or less are preferred for all high accuracy installations. Troughing angles of 45° are acceptable under certain conditions (please check with NYANCELL).

d. Training Idlers:

It is extremely important that the belt tracks centrally from no load to full load conditions. Training idlers are normally accepted if located at least 18 m (60 ft) either side of the scale-mounted idlers. Return belt training idlers are acceptable in most applications.

e. Idler Alignment:

The scale mounted idlers and a minimum of three idlers (five idlers for high accuracy systems) to either side should be dimensionally aligned. It is the installation of these idlers that is the most critical. Good idler alignment throughout the entire conveyor is important to ensure adequate and true belt tracking under all load conditions.

The application criteria we have recommended simply cannot be followed on every conveyor. On some installations you have to make a few compromises. On typical process monitoring and control applications, the effect on weighing accuracy may not be of great concern. On certified weighing installations, all criteria must be considered important.

Assuming you have selected good belt conveyor scale hardware and applied it in compliance with these guidelines, you should now have an installation that performs reliably and provides the weighing accuracy you expected. On-going performance is, of course, dependent on continuing maintenance.

Figure 18

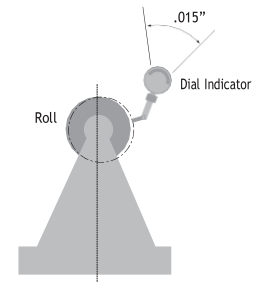
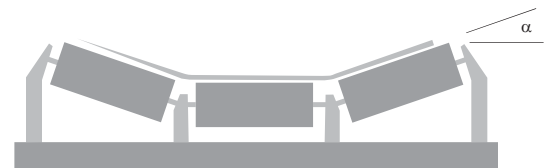

Figure 19



$\alpha = 0^\circ$ to 35° Preferred.
 $\alpha = 45^\circ$ Acceptable under certain conditions

Chapter 7

Continuing Maintenance

Inspection of Belt Conveyor Scale Area

Belt conveyor scales may be expected to operate satisfactorily and hold calibration for weeks with a minimum of maintenance; however, if the user wants the full benefit of the belt conveyor scale, maintenance of the conveyor system and belt conveyor scale area should get adequate attention. One of the major problems is lack of good housekeeping. Keeping the belt conveyor scale area clean should be a primary consideration, particularly in applications where excessive spillage occurs. The cause of spillage should be investigated and eliminated where possible. It must be kept in mind that most belt conveyor scale systems are exposed to weather, overloading, etc. Apart from housekeeping, alignment of the troughing rollers should be regularly checked. Normal wear may cause misalignment, but so can the settling of foundations. Proper functioning of the gravity-type take-up should be checked regularly.

Periodic Calibration

Frequent zero calibrations may be impractical although it is recommended to do a daily zero calibration or zero balance. A change in zero balance can be expected over a long period of time due to material buildup on the carriage or belt and idler wear. Zero calibration should only be performed by making a whole number of revolutions. The belt weight variance will be compensated for only if whole number of revolutions are used for zero calibration. Zero shifts in the order of 0.1 to 0.2% of full scale are normally the result of major weather changes, material buildup on the weighbridge, belt tracking, etc. Zero shifts of a larger magnitude normally are conveyor belt related and should be corrected prior to zero calibration. Most belt conveyor scale weighing errors result from improper zero calibration and lack of understanding of factors causing zero calibration shifts or errors.

Belt conveyor scale systems may need regular zero calibrations; however, their calibration curve (span) will not change. When a span calibration check reveals a deviation from the span reference constant, its cause is most probably in the mechanical parts of the belt conveyor system. The only way to obtain an accurate span setting is to conduct a material test. Following a material test, a span calibration factor will be applied to one or more simulated span calibration methods for subsequent span checks. No simulated test is known which is equivalent to a material test. Quite often, a material test is not possible and span calibration can only be performed by using a test chain, test weight, or electronic span R-Cal. Although test chains and /or weights can be expensive and may be difficult to handle, they can provide a better calibration than electronic SPAN (R-Cal) due to application of actual stresses on to the weighing system. Electronic calibration (R-Cal) is an acceptable alternative for installations with limited access, reduced accuracy requirements or economic limitations.

Accurate record keeping is an important step in any maintenance and calibration program. Without records, severe misalignment and errors due to required mechanical maintenance may go undetected for a lengthy period of time. Accurate history would reveal a problem of this nature during required routine calibrations.



Chapter 8

Special Considerations for Weight Agreement Scales (Certifiable Belt Scale Installations)

Introduction

The purpose of this section is to provide the user with a basic understanding of the responsibilities when using a belt conveyor scale that is to be certified or sealed by a regulatory agency.

Quite often, rules and regulations pertaining to installation, testing and use of the belt conveyor scale have been overlooked until it is to be tested and approved. Unfortunately, in most cases, this is too late, resulting in an unacceptable installation.

Compliance

Prior to use, the installer must certify to the owner that the scale meets the requirements set forth in NIST HB44 and AAR scale HB when applicable. Material load testing and accuracy verification can only be conducted by an official with statutory authority to determine if a scale is in compliance.

A complete understanding of the user and testing requirements is a must when designing a belt conveyor scale system. Copies may be obtained by writing to the appropriate regulatory agency. Knowledgeable belt conveyor scale manufacturers can help you in obtaining this information.

Testing Procedures

All belt scales must be material tested before being used for weight agreements. Two, three or more successive material tests may be required to achieve acceptance accuracy and demonstrate repeatability of the belt scale system. Material testing can be a costly item if not planned for; therefore, it is extremely important to consider and plan for this requirement as early in the system design as possible. It is strongly suggested that an on-site material test system be incorporated with the belt scale system in an effort to reduce excessive cost associated with time and adverse weather conditions which may occur during material testing.

Only a static scale, whose accuracy has been verified prior to use, may be used for material testing. In-motion track scales and portable scales are not acceptable.

Following a material test, one or more methods of simulated testing is employed to ensure repeatability and maintenance accuracy of the belt scale system until the next material test is required. Material tests are normally required on a semi-annual or annual basis. Refer to the appropriate regulation for the acceptable method of simulated testing.

Commitment and Responsibility:

Regulations allow for three areas of responsibility:

1. Equipment Specifications (Manufacturer)
2. Testing Procedure and Tolerance (Regulatory Agency)
3. Material Handling and Belt Scale Installation (User)

The belt scale manufacturer must assure the user and regulatory agency that the selected belt scale has been designed to meet the specifications and acceptance tolerance and will maintain the maintenance tolerance, provided that the belt scale is installed, tested and operated in accordance with the manufacturer's written instructions and the regulatory agency's written instructions.

The official with statutory authority has the authority to approve the use of belt scales for weight agreements following an accepted material and simulated testing procedure.

The user is responsible for the design, construction, operation, material testing (including all arrangements) and maintenance of the belt scale system. The ultimate weight agreement is between the user and the regulatory agency. All costs incurred for these requirements are the user's responsibility.

Conclusion

The intent is not to describe a step-by-step procedure for certification approval but to give the user a basic knowledge of the requirements for approval. Approval is for the entire material handling system of which the belt scale is one component.

Belt scale manufacturers and regulatory agencies will assist the user in any way possible to obtain approval, provided the material handling system is capable of approval.

Product Support

From design to shipment and beyond, NIYANCELL supports its products with a full range of activities. Our large, creative staff of electrical, mechanical and software engineers allows us to maintain our leadership with new developments in technology and machine design. Our extensive customer service organization is dedicated to providing users with technical support, field service and prompt parts delivery when needed. We are dedicated to providing customers with quality products and we are proud to have been awarded formal certification to the quality standards of the International Standards Organization (ISO 9001).



About NIYANCELL Scientific Bulk Weighing and Monitoring Products

The NIYANCELL Scientific line of industrial in-motion weighing, inspection, monitoring and control equipment is used for process control, production monitoring and automation. Our products are marketed worldwide to the coal and minerals mining, cement, construction, aggregates, electric utilities, chemical processing, plastics and food industries, among others.

Our bulk weighing and monitoring product line includes conveyor belt scales, weighbelt feeders, tramp metal detectors, coal and mineral sampling systems, level indicators, conveyor safety switches and a variety of other specialty process control instruments. All products are ISO 9001 certified.

Service and Support

We offer a complete array of services designed to help you gain a competitive advantage. We provide premium, customized, around-the-clock support with guaranteed response time at a price that meets your budget. We appreciate your business and will help you obtain the maximum value of your technology investment.

We provide the training you need to get the most from our NIYANCELL Scientific products and services. We offer certification training on our products, as well as custom training tailored to your operation's specific needs. We can also help you enhance your maintenance, troubleshooting and repair programs.

We are committed to developing new technologies and creating top-of-the-line parts, accessories and consumables that enable you to extend the capability of your products, ensure that they keep pace with advancing technology, and achieve the results you require. We can also retrofit your aging equipment to enhance its performance and functionality, eliminating the need to retrain personnel on new equipment.

The bottom line is that we are dedicated to the highest level of customer satisfaction.

Commitment to Quality

We strive to provide competitively priced, defect-free products and services that meet our customers' requirements by the promised delivery date.

Customer Satisfaction

We are dedicated to the highest level of customer satisfaction. Our pledge is to work with you, the customer, to provide customized solutions to your specifications, needs and expectations.



Type: WF/WB 400/I/V

WEIGHING CONTROLLER NIYANCELL

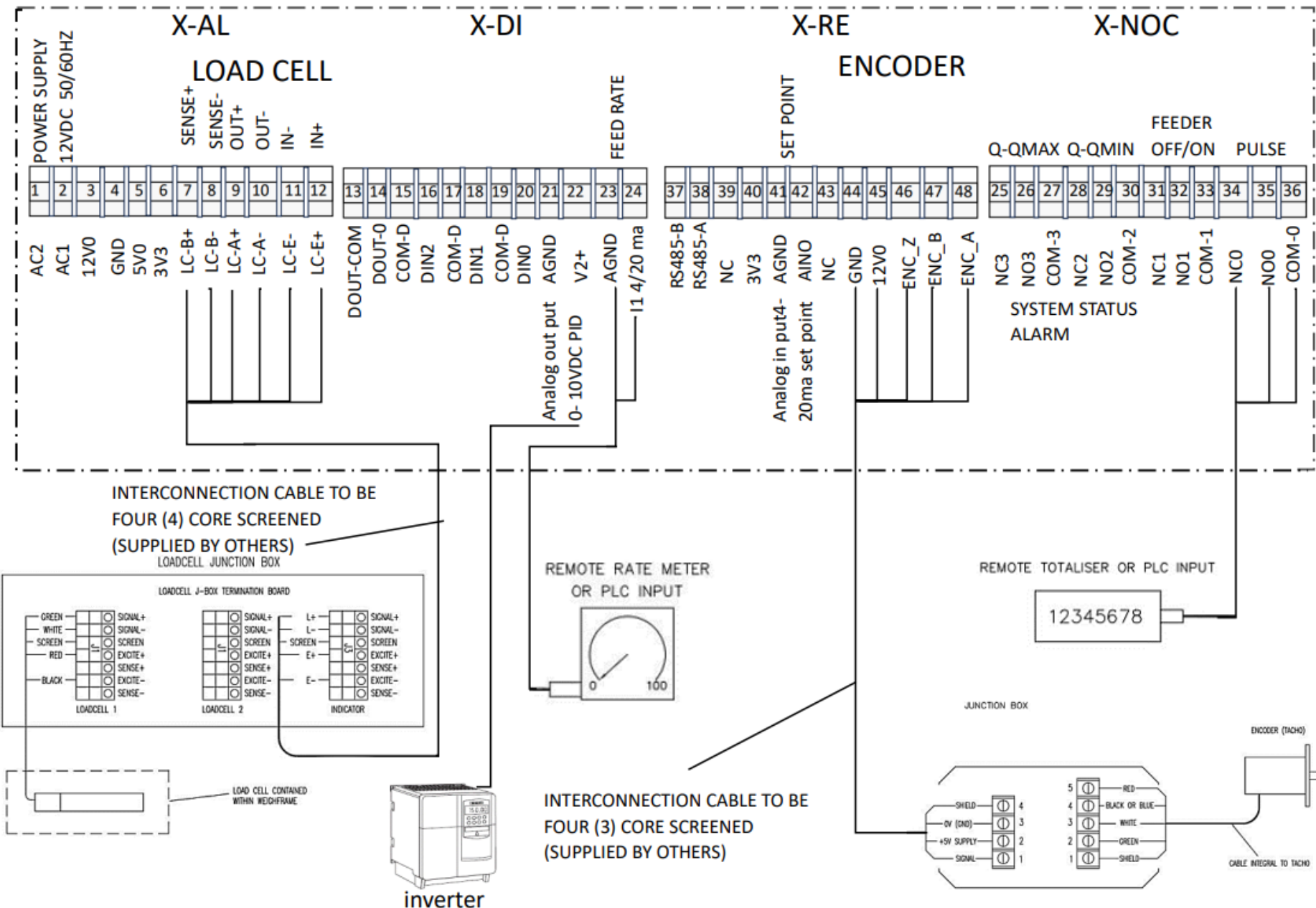



WWW.NIYANCELL.COM



Ritter Strasse 20-26 04509



Leipzig Germany

+49 341 2564757



Info@NIYANCELL.COM

DISTRIBUTED BY:

